

FICHE D'HOMOLOGATION HOMOLOGATION FORM



COMMISSION INTERNATIONALE DE KARTING - FIA



SYSTÈME DE FREINAGE / BRAKING SYSTEM

Constructeur	<i>Manufacturer</i>	MGR Group Srl.
Marque	<i>Make</i>	MGR Group Srl.
Modèle	<i>Model</i>	Tripmatic 100
Catégorie	<i>Category</i>	Sans boîte de vitesses/Non-gearbox
Durée de l'homologation	<i>Validity of the homologation</i>	6 ans / years
Nombre de pages	<i>Number of pages</i>	3


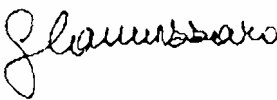

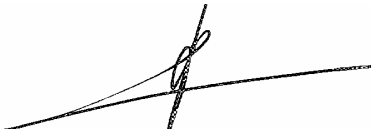
La présente Fiche d'Homologation reproduit descriptions, illustrations et dimensions du système de freinage au moment de l'homologation CIK-FIA. Le Constructeur a la possibilité de les modifier, mais seulement dans les limites fixées par le Règlement CIK-FIA en vigueur.

This Homologation Form reproduces descriptions, illustrations and dimensions of the brake system at the moment of the CIK-FIA homologation. The Manufacturer may modify them, but only within the limits set by the CIK-FIA Regulations in force.

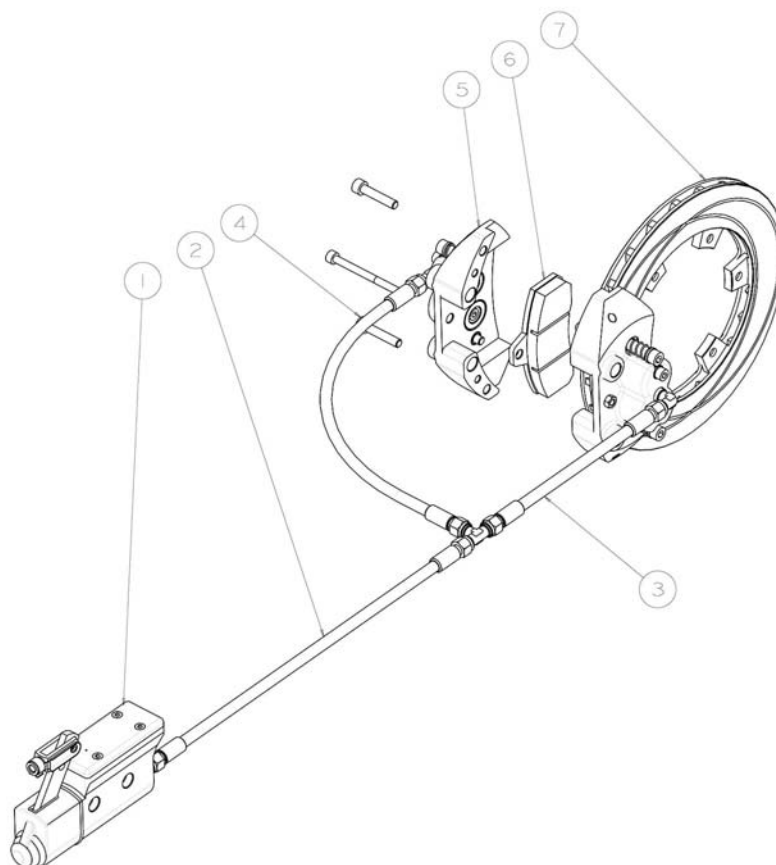


PHOTO VUE DE DESSUS DU SYSTÈME COMPLET

PHOTO FROM ABOVE OF COMPLETE SYSTEM

Signature et tampon de l'ASN <i>Signature and stamp of the ASN</i>	Signature et tampon de la CIK-FIA <i>Signature and stamp of the CIK-FIA</i>
 	 

A	DESSIN TECHNIQUE DU SYTÈME DE FREINAGE	A	TECHNICAL DRAWING OF BRAKING SYSTEM
----------	--	----------	-------------------------------------



N°	DÉSIGNATION	DESIGNATION	Référence catalogue
			Catalogue reference number
1	POMPE DE FREIN	BRAKE PUMP	2900
2-3-4	TUBE DE FREIN	BRAKE PIPE	3000
5	PINCE DE FREIN	BRAKE CALIPER	2800
6	PLAQUETTES DE FREIN	BRAKE PADS	2835
7	DISQUE DE FREIN	BRAKE DISC	2400

B		DESCRIPTION TECHNIQUE DU SYTÈME DE FREINAGE			B		TECHNICAL DESCRIPTION OF BRAKING SYSTEM		
Régulateur de freinage <i>Braking regulator</i>		<input type="checkbox"/> oui / yes		<input checked="" type="checkbox"/> non / no		Emplacement <i>Location</i>		_____	
		Avant / Front			Arrière / Rear				
Nombre de maîtres-cylindres <i>Number of master cylinders</i>		_____					1		
Alésage <i>Bore</i>		_____ mm					22 mm		
Nombre de pistons <i>Number of pistons</i>		_____			Par roue <i>Per wheel</i>		4		
Alésage <i>Bore</i>		_____ mm					19x2 22x2 mm		
Nombre de plaquettes <i>Number of pads</i>		_____			Par roue <i>Per wheel</i>		2		
Nombre d'étriers <i>Number of calipers</i>		_____			Par roue <i>Per wheel</i>		1		
Matériau des étriers <i>Caliper material</i>		_____					ALU		
Disques ventilés <i>Ventilated discs</i>		<input type="checkbox"/> oui / yes		<input type="checkbox"/> non / no		<input checked="" type="checkbox"/> oui / yes		<input type="checkbox"/> non / no	
Épaisseur du disque neuf <i>Thickness of new disc</i>		_____ mm			+/- 1 mm		12 mm		+/- 1 mm
Ø extérieur du disque <i>External Ø of the disc</i>		_____ mm			+/- 1.5 mm		200 mm		+/- 1.5 mm
Ø extérieur de frottement des plaquettes <i>External Ø of pads rubbing surface</i>		_____ mm			+/- 1.5 mm		198 mm		+/- 1.5 mm
Ø intérieur de frottement des plaquettes <i>Internal Ø of pads rubbing surface</i>		_____ mm			+/- 1.5 mm		133 mm		+/- 1.5 mm
Longueur hors-tout des plaquettes <i>Overall length of the pads</i>		_____ mm			+/- 1.5 mm		90 mm		+/- 1.5 mm
Photo du frein avant : étriers et disques seulement <i>Photo of front brake: calipers and discs only</i>					Photo du frein arrière : étrier(s) et disque(s) seulement <i>Photo of rear brake: caliper(s) and disc(s) only</i>				
					